

ABSOLUTE MAXIMUM RATINGS

Item	Symbol	Min.	Max.	Unit
Supply Voltage(Logic)	Vdd - Vss	-0.3	4.0	V
Supply Voltage(LCD)	Vlcd	-0.3	18.0	V
Input Voltage	Vi	-0.4	Vdd + 0.5	V
Operating Temp.	Topr	-25	75	°C
Storage Temp.	Tstg	-30	80	°C

MECHANICAL DATA

Item	Max.	Unit
Module Size (W X H X T)	82.2 X 76.0 X 9.0	mm
Viewing Area(W X H)	60.0 X 60.0	mm
Dot Pitch(W X H)	0.34 X 0.34	mm
Dot Size(W X H)	0.32 X 0.32	mm
View Angle	6 O'Clock	

ELECTRICAL CHARACTERISTICS (Vdd=3.0V±0.3V)

Item	Symbol	Test Condition	Min.	Typ.	Max.	Unit
Input High Voltage	Vih	--	0.8Vdd	--	--	V
Input Low Voltage	Vil	--	--	--	0.2Vdd	V
Output High Voltage	Voh	--	0.8Vdd	--	--	V
Output Low Voltage	Vol	--	--	--	0.2Vdd	V
Current consumption	Idd	Vdd=3.0V	--	725	1087	μA
LCD Driving Voltage	V0	Ta=25 °C	--	16.5	--	V

PIN CONNECTIONS

Pin	Symbol	Function
1	VSS	Ground
2	A0	"L": Control data; "H": Display data
3	WR	Write Select Signal
4	RD	Read Enable Signal
5	XCS	Chip select pin
6	RST	Reset signal input
7	VDD	Power Supply for Logic(+3.3V)
8-15	D0~D7	Display Data Signal
16	LEDK	Backlight Ground
17	NC	
18	LEDA	Power Supply for Backlight(+3.3V)

BLOCK DIAGRAM

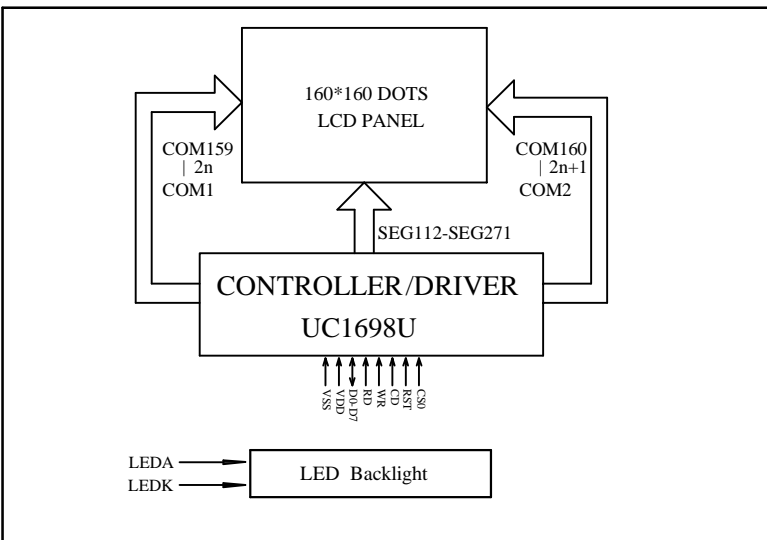

LCD Type

LCD Color	Backlight
FSTN/Positive/Transflective	WHITE,If=80mA